

E-Z-GO RXV Long Travel Lift Kit
2008 & Newer Gas
Installation Instructions
Part# 7495
U.S.PAT. 7581740



ITEM	QTY
A. JAKES SUB-FRAME	1
B. TIE ROD EXTENSION	1
C. STEERING EXTENSION	1
D. FRONT HARDWARE KIT	1
E. CHROME COIL OVER SHOCKS	2
F. PASSENGER SIDE TOP A-ARM	1
G. DRIVER SIDE TOP A-ARM	1
H. PASSENGER SIDE BOTTOM A-ARM	1
I. DRIVER SIDE BOTTOM A-ARM	1
J. PASSENGER SIDE TOP SHOCK MOUNT	1
K. DRIVER SIDE TOP SHOCK MOUNT	1
L. PASSENGER SIDE SPINDLE	1
M. DRIVER SIDE SPINDLE	1
N. REAR U-BOLT PLATES	2 ea
O. PASSENGER SIDE REAR SHOCK MOUNT	1 ea
P. DRIVER SIDE REAR SHOCK MOUNT	1
Q. REAR U-BOLTS	2
R. REAR RISERS	2
S. REAR LIFT HARDWARE KIT	1
T. DRIVER SIDE BRAKE CABLE MOUNT	1
U. FRONT MOTOR MOUNT	1
V. WARNING LABEL	1 (NOT PICTURED)

 *Always wear appropriate eye protection!*

FRONT ASSEMBLY

1. Place the cart on jack stands.
2. Remove the stock front bumper from the cart. Save the bumper and bolts for reinstallation.
3. Remove the stock wheel hubs & wheels/tires. Save the stock wheel hubs for reinstallation.
4. Remove the tie rod ends from both the driver and passenger side of the spindles.
5. Remove the top stock shock bolts from both the driver and passenger side of the cart. This will allow you to drop the stock struts. Remove the bolts that are holding the lower a-arms to the frame of the cart. Now remove the strut assembly from both the driver and passenger side of the cart.
6. Unbolt the steering shaft from the steering U-joint and unbolt the steering box from the frame of the cart as shown in FIGURE 1.
7. Remove the steering box from the cart and remove the stock steering U-joint from the steering box as shown in FIGURE 2.
8. Using the supplied M10x40 flanged bolts and locknuts bolt the steering box to the new sub-frame (ITEM A) as shown in FIGURE 3.
9. Loosely install the sub-frame (ITEM A) to the cart using the supplied 5/8 x 1 1/2 bolt and locknut. Loosely install the rear portion of the sub-frame to the stock square tubing frame using the supplied 3/8 u-bolts and locknuts as shown in FIGURE 4. DO NOT SECURELY TIGHTEN AT THIS TIME.

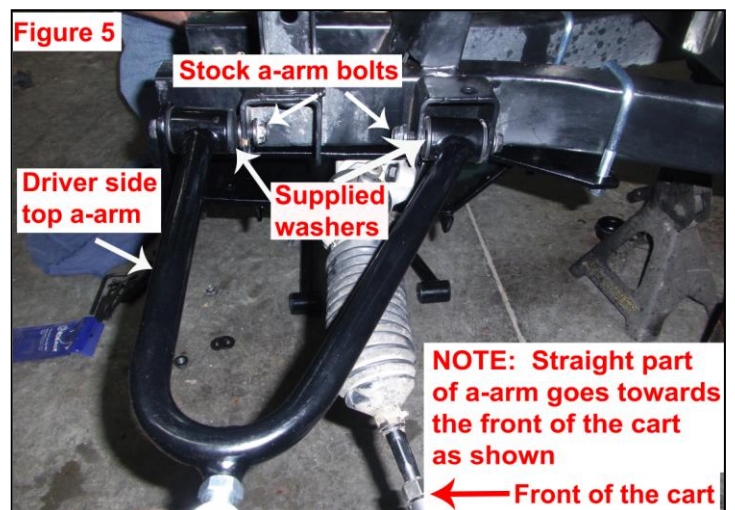
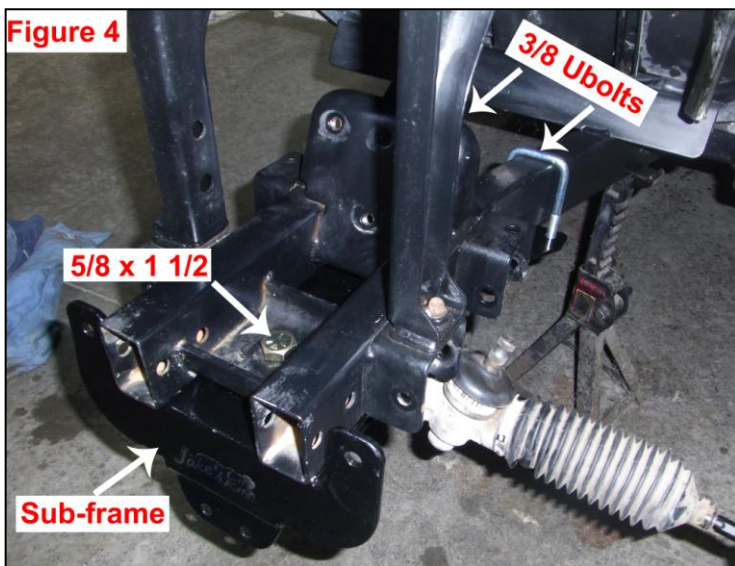
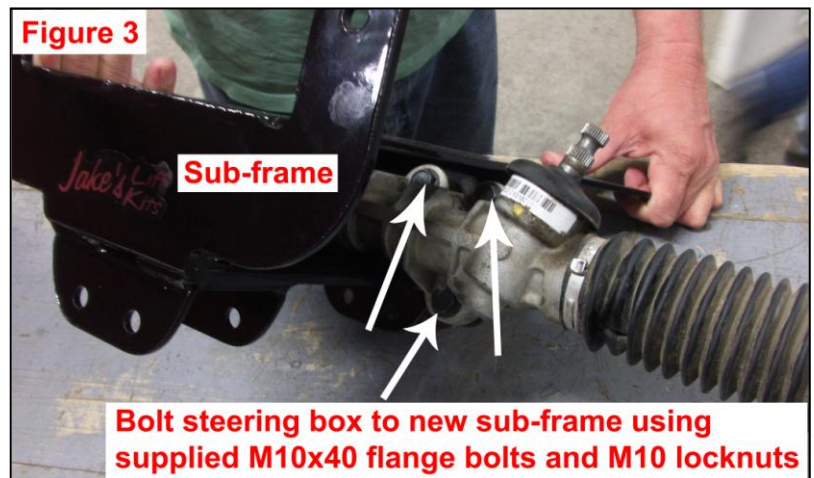
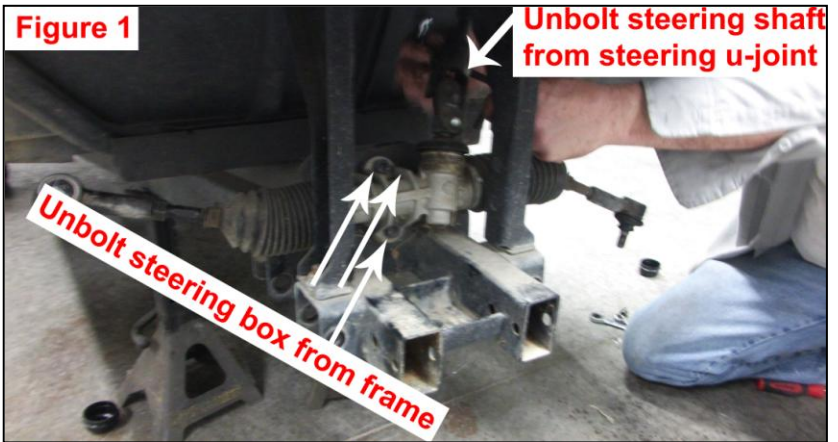

- Using the stock bolts and supplied black metric washers install the new top A-arms (ITEMS F&G) to the stock a-arm location as shown in FIGURE 5. NOTE: The a-arms are side specific. The straight tube goes towards the front and the angled tube goes towards the rear of the cart as shown in FIGURE 5. Install the black metric washers to the rear side of the front mount and the front side of the rear mount on both the driver and passenger side a-arm as shown in FIGURE 5. Securely tighten.

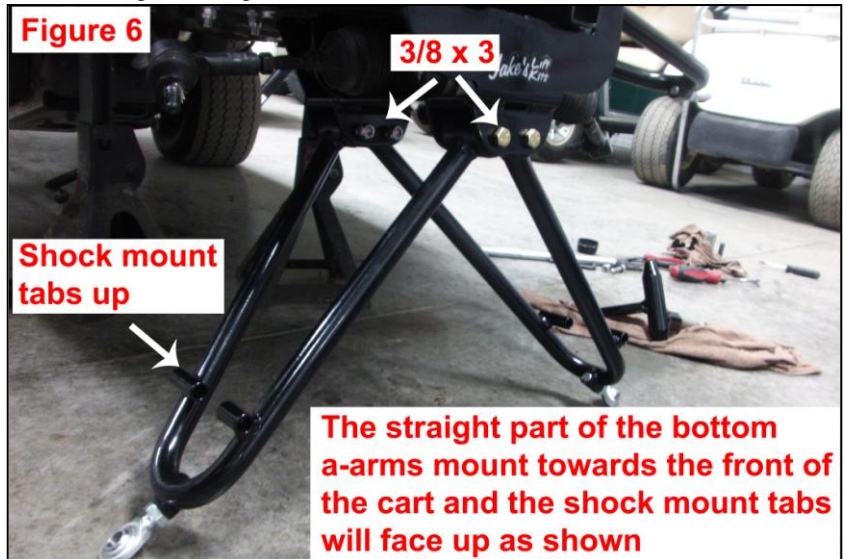

- Securely tighten the u-bolts that are holding the sub-frame to the frame of the cart at this time. Make sure you evenly tighten both sides of the u-bolts. Securely tighten the 5/8 x 1 1/2 bolt sub-frame bolt at this time.

- Using the supplied 3/8 x 3 bolts and locknuts install the bottom a-arms (ITEMS H&I) to the sub-frame as shown in FIGURE 6. NOTE: The bottom a-arms are side specific. The straight part of the a-arm mounts to the front of the cart and the angled part of the a-arm mounts towards the rear of the cart. The shock mount tabs on the a-arms must face up as shown in FIGURE 6.

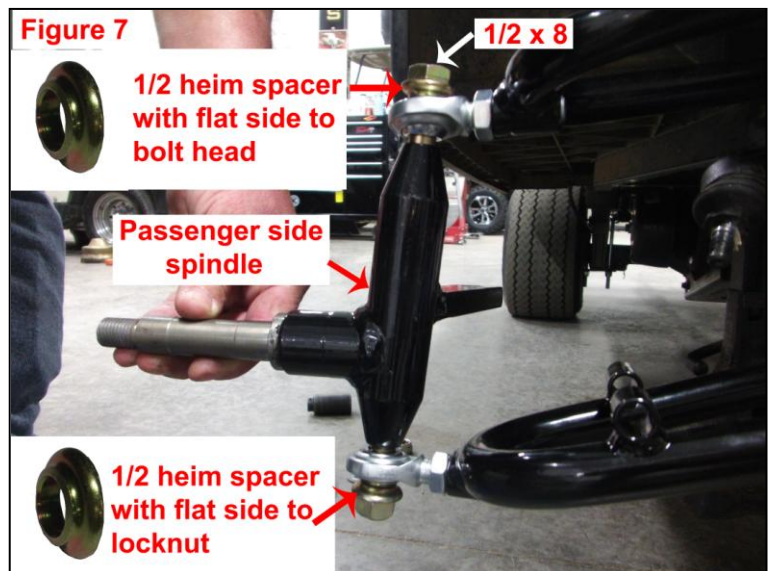

- Using the 1/2 x 8 bolts, locknuts & heim spacers install the driver and passenger side spindles (ITEMS L&M) to the top and bottom a-arms as shown in FIGURE 7. NOTE: The spindles are side specific. The axle is on the bottom portion of the spindles and the steering arms go towards the rear of the cart and angle towards the center as shown in FIGURE 7. NOTE: Two heim spacers are installed on each driver and passenger side spindle. On the top the heim spacer installs between the bolt and heim swivel joint with the flat side towards the bolt head. On the bottom the heim spacer installs between the locknut and heim swivel joint with the flat side towards the locknut as shown in FIGURE 7.

- Push the driver side tie rod end on the steering box completely in towards the center of the cart. Using a colored marker put a mark on the spline of the steering box. Slowly pull out on the driver side tie rod while watching the splines turn on the steering box. Stop when the mark makes 1 1/2 revolutions. This centers your steering. Using the stock hardware install the tie rod end to the driver side steering arm on the spindles.

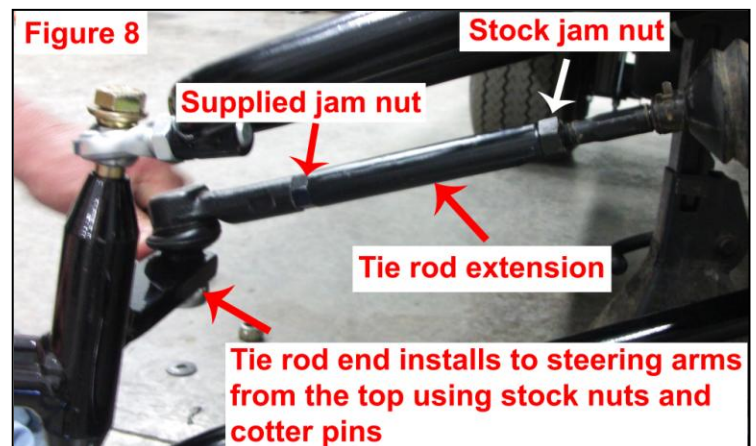

- Remove the tie rod end from the passenger side tie rod. Leave the stock jam nut on the tie rod. Using the supplied tie rod extension and jam nut (ITEM B) install the tie rod extension to the stock tie rod. Reinstall the stock tie rod end to the tie rod extension. Using the stock nut and cotter pin install the tie rod end to the passenger side steering arm as shown in FIGURE 8.

- Remove the tie rod end from the passenger side tie rod. Leave the stock jam nut on the tie rod. Using the supplied tie rod extension and jam nut (ITEM B) install the tie rod extension to the stock tie rod.

Reinstall the stock tie rod end to the tie rod extension. Using the stock nut and cotter pin install the tie rod end to the passenger side steering arm as shown in FIGURE 8.

16. Install the supplied steering extension (ITEM C) to the stock steering universal using the stock pinch bolt as shown in FIGURE 9. Slide the universal on the splines of the steering box and the steering extension on to the steering shaft as shown in FIGURE 10. NOTE: Make sure steering wheel is straight before sliding steering extension on to the steering shaft.

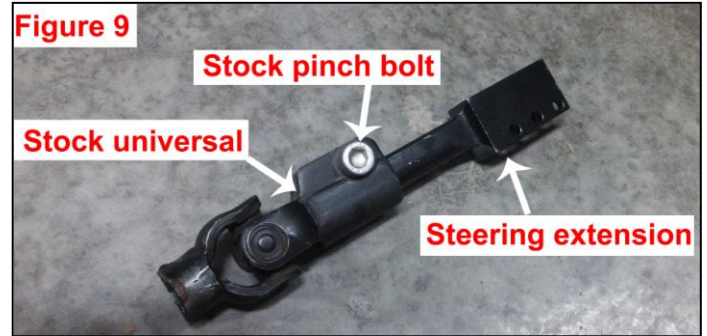

17. Using the supplied $\frac{1}{4} \times 1 \frac{1}{2}$ bolts, washers, & locknuts securely tighten the steering extension to the steering shaft as shown in FIGURE 10.

18. Securely tighten the bottom stock pinch bolt to secure the stock universal to the steering box.

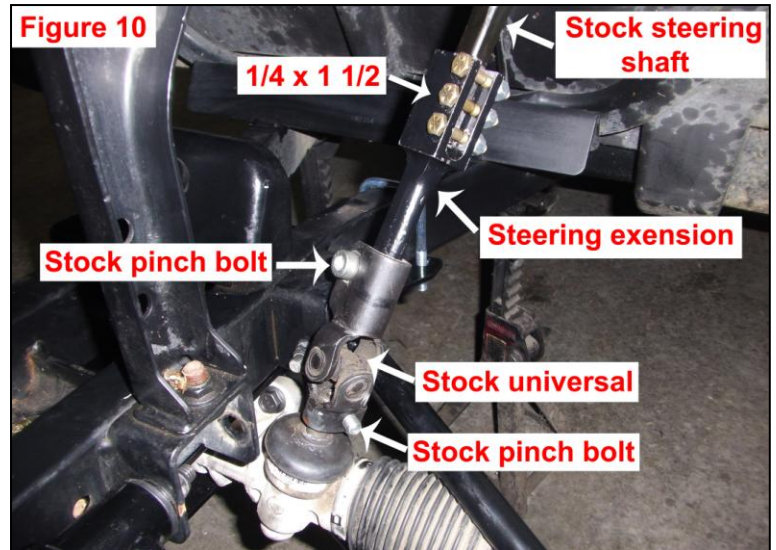

19. Using the supplied $\frac{3}{8} \times 1$ bolts, washers, & locknuts and stock top shock mount bolt mount the shock mount plates (ITEMS J&K) to the frame of the cart as shown in FIGURE 11. NOTE: The shock mount plates are side specific. The tab on the bottom of the shock plates goes towards the rear of the cart. The bottom tab mounts to the upper stock hole in the frame channel as shown in FIGURE 11. The top of the shock plates mount to the front of the top channel as shown in FIGURE 11 and the stock top shock bolt must be installed from the back side of the channel as shown in FIGURE 11. Securely tighten.

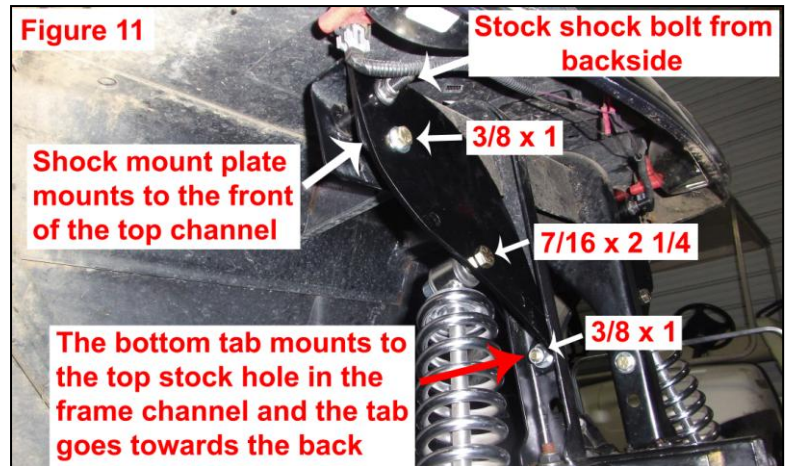

20. Mount the supplied shocks (ITEM E) to the shock mount plate using the supplied $\frac{7}{16} \times 2 \frac{1}{4}$ bolts, washers, & locknuts as shown in FIGURE 11. NOTE: There are 3 different holes for mounting the top of the shocks. The bottom hole will provide the softest ride, the middle hole will provide a stiffer ride and the top hole will provide the stiffest ride. Securely tighten.

21. Using the supplied $\frac{7}{16} \times 5 \frac{1}{2}$ bolts & locknuts and tapered spacers install the bottom of the shocks to the bottom a-arms as shown in FIGURE 12. NOTE: The tapered spacers go to both the front and rear of the shocks with the taper going away from the shock.

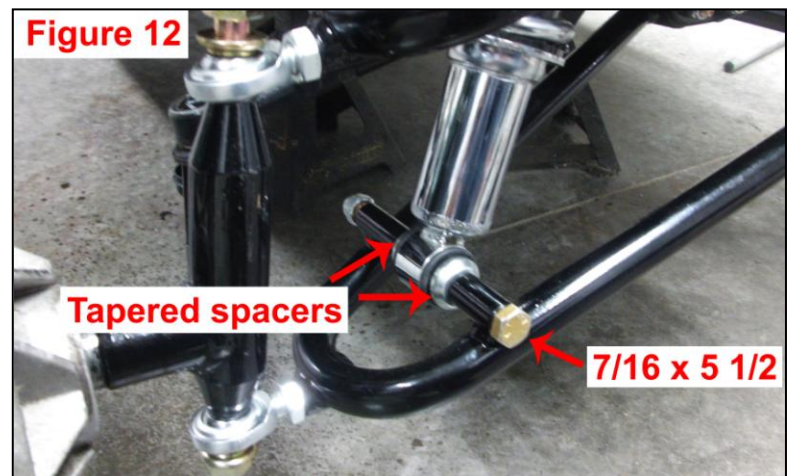

22. Reinstall the stock hubs to the new spindles using the stock hardware.

23. Install Jake's recommended 23x10.5x12 or 22x11x10 tires on a 3x5 or 3x4 offset wheel.

24. Go back through the lift kit and double check all nuts/bolts are securely tightened and all cotter pins are reinstalled.

25. Adjust the front end for proper alignment. The toe should be set to $\frac{1}{8}$ - $\frac{1}{4}$ in. If you need to adjust the camber of the wheels uninstall the front spindles and adjust the heim ends on the a-arms. When doing this make sure you retighten jam nuts.

26. Using the supplied template mark both sides of the stock front bumper as shown in FIGURE 13. Using a jig saw or band saw cut along the template line. Using the stock hardware reinstall the front bumper.

Figure 13



Using the supplied template mark each side of the stock bumper and cut for clearance.



Template for cutting front bumper
***Cut out template**
***Mark bumper as shown in FIGURE 13**

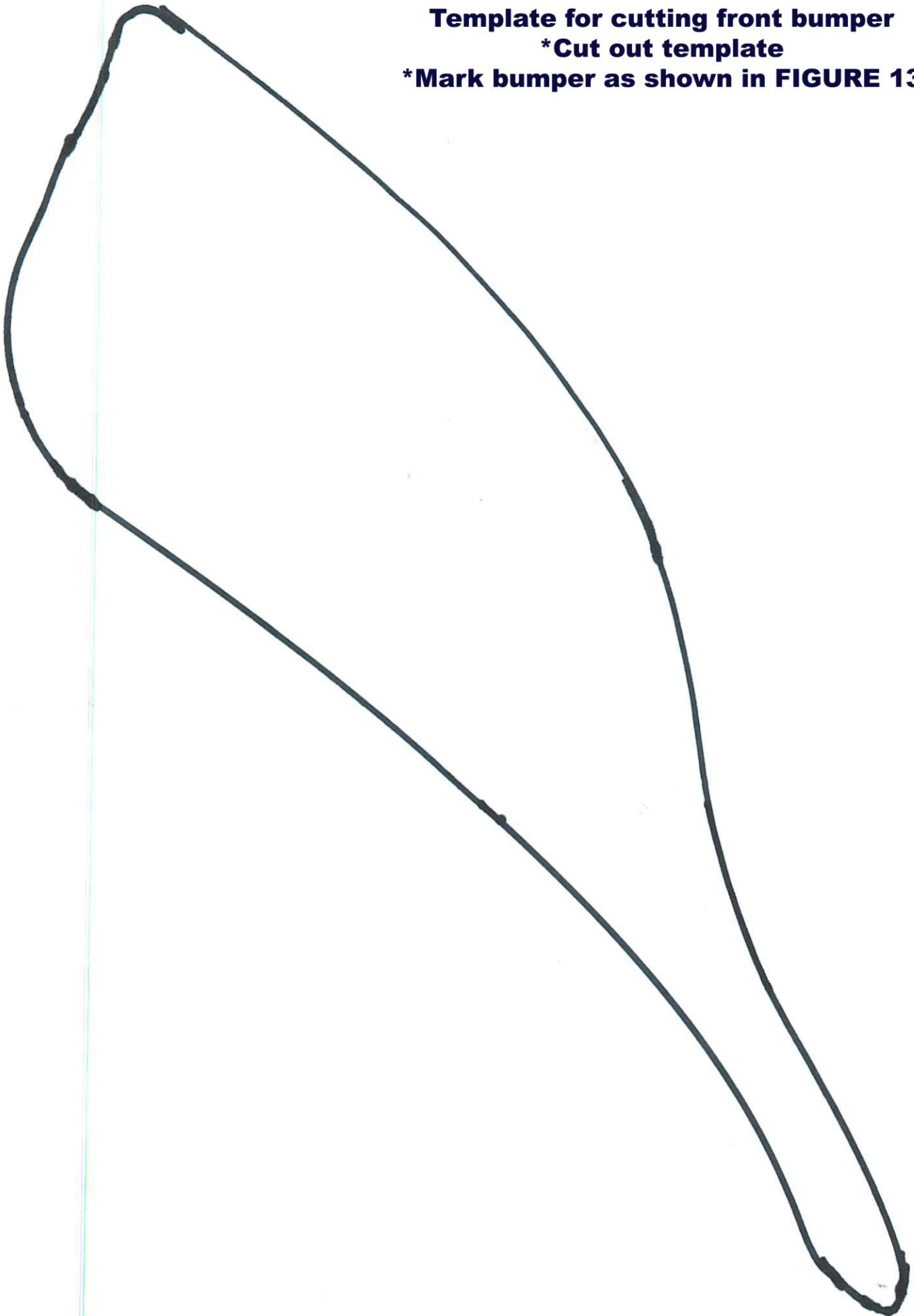

REAR ASSEMBLY

1. Jack up the rear end of the cart and place jack stands on the frame in front of the springs. You will be installing larger wheels and tires so raise the cart high enough to accommodate the additional height. Place a car jack under the rear differential.
2. Remove the wheels and tires.
3. Place a jack stand under the motor and unbolt the front motor mount from the frame. Place jack stands under the motor to secure.
4. Unbolt the bottom of the shocks.
5. You will need to unhook rear brake cables and re-route them. We recommend cutting a hole in the driver side of the plastic frame, under the battery (remove battery) as shown for re-routing the driver side brake cable as shown in FIGURE 1. The passenger side brake cable needs rerouted to give you the length you will need. You do not have to cut the floor on the passenger side only the driver side.

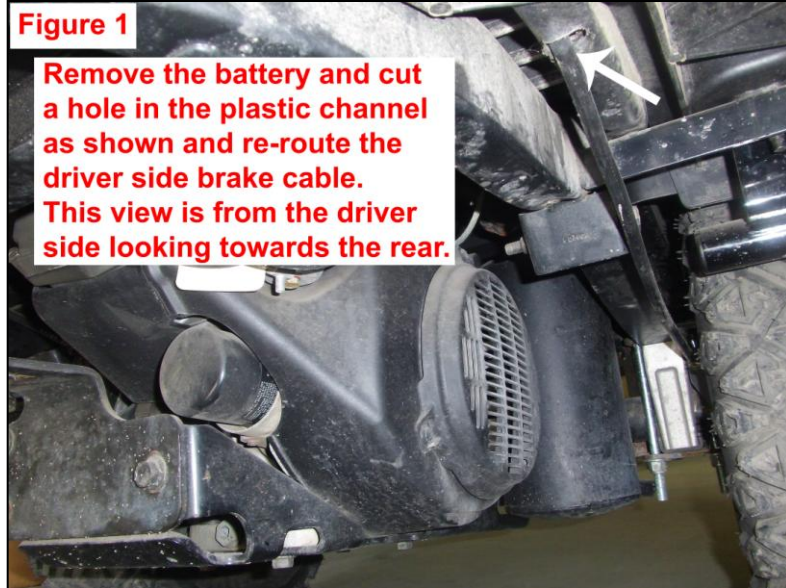

6. Remove the **DRIVER** side brake drum cover from the car. Unbolt the 2 front bolts that are holding the stock brake cable mount to the car. Replace the stock brake cable mount with the newly supplied brake cable mount (ITEM T) with the stock hardware. Reinstall the stock brake drum cover with the stock hardware.
7. Unbolt the rear leaf springs from the front and rear mounts. Save the bolts for reinstallation.
8. Put the aluminum rear risers (ITEM R) on top of the axle as shown. **NOTE: The thinner leg of the riser goes towards the rear of the cart.**

9. Place the leaf springs on top of the risers and loosely bolt to the stock leaf mounts using the stock hardware.
10. Place JAKES rear shock plates (ITEMS O & P) on top of the leaf springs with the shock mount holes facing the rear of the cart and towards the center. Using the supplied U-bolts (ITEM Q) & 1/2" nuts (ITEM S) mount the shock plates to the rear risers with the leaf springs between them. The U-Bolt plates (ITEM N) mount on the bottom of the assembly as shown. Make sure you tighten these bolts evenly.

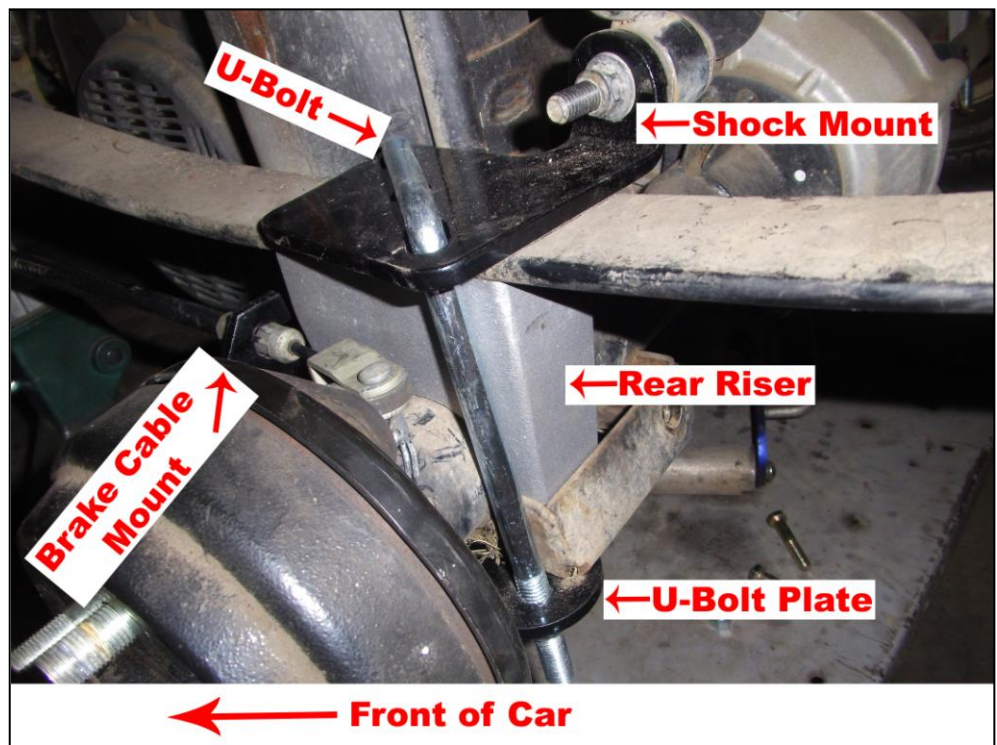

11. Attach the bottom of the shocks to JAKES new shock mounts on the rear shock plates using the supplied nuts and bolts (ITEM S).
12. Bolt the new supplied motor mount (ITEM U) to the stock motor mount location on the frame using the supplied hardware.

13. Using the supplied (or stock) motor mount bolt, stock washers, & stock retainers bolt the new drop motor mount to the stock motor mount from the engine assembly as shown.
****BARELY SNUG
 MOTOR MOUNT DO NOT OVERTIGHTEN****
14. Reinstall brake cables to brake cable mounts. Securely tighten all bolts at this time.
15. Install Jake's recommended 23x10.5x12 or 22x11x10 tires on a 3x5 or 3x4 offset wheel.
 NOTE: Your stock wheels and tires will **not** work!



Included is a warning label (Item V) which is to be placed on the steering column or another visible area and is to be read by all operators.

Indemnification And Insurance Agreement

High Performance Enhancement Kit purchaser assumes sole and entire responsibility for, and shall indemnify and save harmless Nivel LLC, from any and all claim, liability, responsibility, and persons or property that may be sustained in connection with the use of any product before or after purchase, including but not limited to high performance enhancement lift kits. The High Performance Enhancement Kit purchaser also shall indemnify Nivel LLC harmless with respect to any and all liability that may be incurred.

Golf Cars are recommended for use only by those aged 16 and older. Golf Cars can be especially hazardous to operate. Always remember that riding and alcohol/drugs don't mix. Never ride on public roads. Never carry more than two passengers (except shuttles and trams). Never engage in stunt driving. Avoid excessive speeds and be particularly careful on difficult terrain. Nivel LLC reserves the right, at any time, to discontinue or change specifications, prices, designs, features, models, or equipment without notice and without incurring any obligation.