

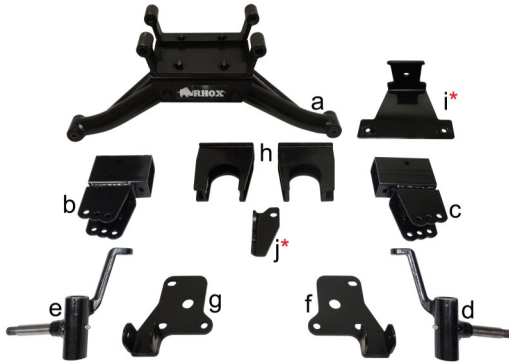

LIFT-507 BMF Lift Kit E-Z-Go RXV Gas or Electric Installation Instructions



Contents of LIFT-507 E-Z-Go RXV BMF Lift Kit:

- a (1 ea.) BMF A-Arm Assembly
- b (1 ea.) Driver Side Shock Tower
- c (1 ea.) Passenger Side Shock Tower
- d (1 ea.) Driver Side Spindle
- e (1 ea.) Passenger Side Spindle
- f (1 ea.) Driver Side Shock Mounting Plate
- g (1 ea.) Passenger Side Shock Mounting Plate
- h (2 ea.) Riser Blocks
- i* (1 ea.) Motor Mount (GAS ONLY)
- j* (1 ea.) Brake Cable Bracket (GAS ONLY)
- k (1 ea.) Box of Hardware (Contents on Next Page)
- l (1 ea.) Instructions

Caution: Please read through the instructions carefully. Installer is responsible for damage if instructions are not followed properly. Look behind each drill or cut location BEFORE YOU DRILL OR CUT. Installer is responsible for damage (i.e. drilling/cutting into a wiring harness, battery, fuel tank etc.). Extra installers will be helpful in some parts of the installation. Please refer to all torqueing specifications on page 2 for installation.

Note: You must install larger tires and wheels once the cart is lifted. Stock wheels will not work. We recommend a 22" tire with a minimum of a 10" offset wheel for use on the RHOX BMF Lift Kit.

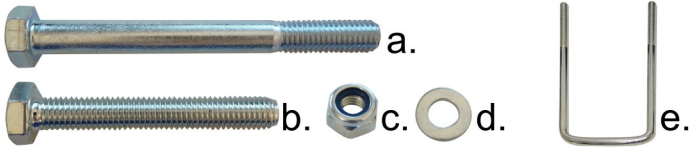

Contents of LIFT-507 Hardware Kit:

<u>ITEM</u>	<u>QTY.</u>	<u>DESCRIPTION</u>	<u>TORQUE REQUIREMENTS</u>
a.	2 ea.	10mm x 110 Hex Head Bolts	38.25 ft. lbs.
b.	2 ea.	10mm x 70 Hex Head Bolts	38.25 ft. lbs.
c.	10 ea.	10mm Nylock Nuts	-
d.	14 ea.	10mm Flat Washes	-
e.	2 ea.	U-Bolts	38.25 ft. lbs.

Installation Preparation (Front of the Cart)

1. Make sure the parking brake is engaged and the key is in the Off position.
2. Electric Carts Only: If your cart has a Tow/Run Switch, place switch in the Tow position.
3. Remove the front bumper by removing the (2) bolts holding it in place. Retain bumper and hardware.
4. Remove the hub caps (if any). Loosen the lug nuts on both front wheels. Do not remove lug nuts.
5. Chock the back of the rear wheels to prevent the cart from moving.
6. Using a jack, safely lift the front end of the cart enough to accommodate the additional height of the larger tires and wheels.
7. Place jack stands securely under the chassis and remove jack.
8. Fully remove the (8) front lug nuts, front tires and wheels. Discard the tires and wheels as they will not be reused.

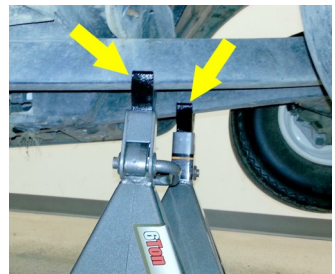

- 9. Remove the dust caps from the front hubs. Retain dust caps.
- 10. Remove the front hubs by removing the flange nut in the center of the hub. Retain hubs and hardware. Keep hubs in a dry, clean, safe place to protect the bearings from debris.



- 11. Disconnect the tie-rod ends from the spindles by removing the safety pin from the tie-rod end. Then remove the crown nut on the tie-rod end. Use a tie-rod end fork to dislodge and remove the tie-rod end from the spindle. Retain hardware.



- 12. Remove the spindles from the shocks as shown in the photo to the right. Discard spindles and retain hardware.



- 13. Disconnect the shocks from the A-arms and the cross frame by removing the bolts holding them in place. Retain shocks and all hardware.

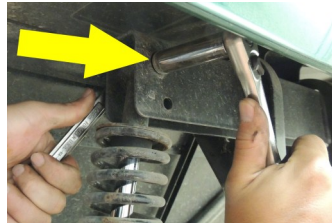

- Remove the A-arms from the chassis by removing the (2) small bolts on each side. Discard A-arms and retain hardware.

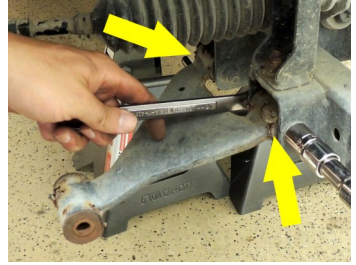

BMF Front Suspension Installation

NOTE: Please refer to page 2 for torquing specifications for included hardware. Please refer to vehicle’s maintenance manual for torquing specifications on reused hardware.

- Identify the driver side shock tower.
- Insert the driver side shock tower into the driver side cross frame as shown below. Push the shock tower upward and toward the cart; to the top of the cross frame.

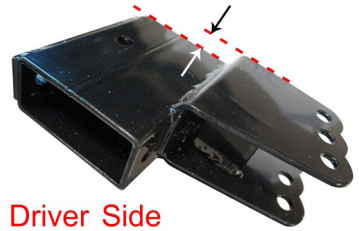

- Align the hole in the shock tower with the hole in the cross frame as indicated in yellow. If needed, use a screwdriver to align the hole.

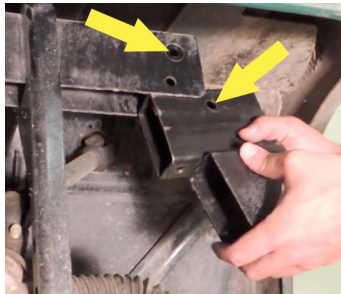

- Insert the Original Bolt from the upper portion of the shock into the aligned hole.



- Insert a marking device through the thru holes in the shock tower as shown. Mark a drill location on the underside of the cross frame.



- Remove the bolt and shock tower from the cross frame.

7. Use a center punch and to mark the location of the hole.
8. Wearing safety glasses, drill a 1/8"-3/16" pilot hole through the cross frame at the marked location.
9. Drill a 13/32" hole through the pilot hole.



10. Reinsert the shock tower into the cross frame. Align mounting holes.
11. Install the shock tower by using the Original Hardware from the upper portion of the shock (yellow arrow) and (1) 10mm x 110 Hex Head Bolt, (2) 10mm Flat Washers and (1) 10mm Nylock Nut (blue arrow).

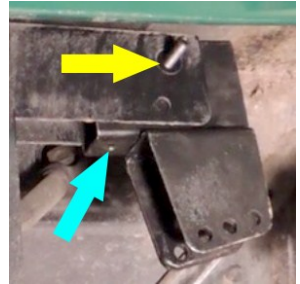

12. Repeat Steps 1-11 for the passenger side shock tower.
13. Position the new BMF A-arm assembly in front of the cart with the *RHOX* plate facing forward.
14. Loosen the (4) bolts on the mounting arms of the A-arm assembly to make installation easier.
15. Using the Original Hardware, bolt the new BMF A-arm assembly to the chassis in the (4) places where the original front suspension was removed.

NOTE: Additional help is recommended during this step to help support the A-arm assembly during installation.



16. Tighten the hardware loosened in Step 14.
17. Mount the shocks to the shock towers using (1) 10mm x 70 Hex Head Bolt, (2) 10mm Flat Washers and (1) 10mm Lock Nut per shock. It is recommended to install it in the center hole position to start. If the camber needs adjusting at the end of the installation, the position can be changed.

NOTE: The larger round mounting tabs of the shocks will face away from the cart.

18. Using the Original Hardware, mount the bottom of the shocks to the BMF A-arms. A rubber mallet can be used to align the A-arm in the mounting tabs.



19. Attach the new BMF spindles to the shocks using the Original Hardware from the stock spindles.



20. Attach the tie-rod ends to the new spindles using the Original Hardware.

21. Reinstall the front hubs and the dust covers that were removed earlier using the Original Hardware.
22. Install the (2) front tires. The stock tires and wheels will not work on the newly lifted cart. Fully tighten the lug nuts on both wheels.

NOTE: It is recommended to use at least 22" tires on a 10" wheel with an offset. The wheel shown is a *RHOX Vegas TIR-RX160* with a *RHOX Mojave* tire, TIR-265.



23. Once the tire and wheels are fully secure, place the jack under the cart. Remove jack stands and lower the cart safely to the ground. Remove the chocks behind the rear wheels.

NOTE: The front bumper will remain off until the camber and toe adjustments are made at the end of the installation.

Installation Preparation (Rear of the Cart)

1. Turn the key to the Off position and lock the parking brake.
2. Electric Carts Only: If your cart has a Tow/Run Switch, place switch in the Tow position.
3. Chock the front of the front wheels to prevent the cart from moving.
4. Remove the hub caps (if any) on the rear wheels. Loosen the lug nuts on both wheels. Do not remove the lug nuts.
5. Place a jack securely under the rear axle. Safely lift the rear end of the cart enough to accommodate the additional height of the larger tires and wheels.
6. Place jack stands under the chassis on both sides of the cart to stabilize it. Lower the jack but do not remove it.
7. Fully remove the (8) rear lug nuts, tires and wheels. Discard the tires and wheels as they will not be reused.



BMF Rear Suspension Installation

Safety Note:

Proper eye and mouth protection should be worn during this section to protect the installer from falling debris when working under the cart.

The rear axle is only held up by the (2) leaf springs and the jack. For safety reasons, complete one side of the suspension at a time. The photos below show the Driver side.

Electric Carts Only:

1. Carefully raise the jack to support the rear axle.
2. Disconnect the bottom of the driver side shock from the axle and push the shock out of the way. Retain hardware.



3. With the rear axle supported by the jack, disconnect the leaf spring at the rear shackle. Retain hardware.

4. Loosen both nuts on the U-bolt then carefully remove the U-bolt. Discard the U-bolt and retain the leaf spring plate.



5. Remove the front portion of the leaf spring by removing the bolt on the front shackle. Remove the leaf spring. Retain hardware.



6. Carefully lower the jack to lower the rear axle away from the chassis. Do not remove the jack stands. They will support the chassis.

7. Place the leaf spring on top of the axle.

8. Reattach the front portion of the leaf spring to the front shackle using the Original Hardware. Do not fully tighten.

9. Place a riser block on top of the axle and under the leaf spring. When oriented correctly, the wider leg will be towards the front of the cart and the pin on the bottom of the leaf spring will seat into the hole on top of the riser block. Slightly loosen the opposite U-bolt and adjust the axle position to help with alignment.

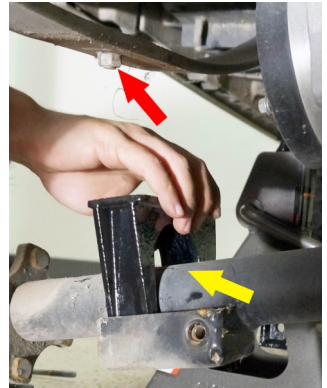
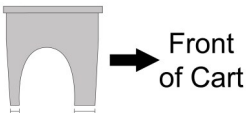

10. Once the spring is seated, identify the new driver side shock mounting plate included in the BMF kit. Place it on top of the leaf spring. The pin will seat in the small hole. The shock mounting tabs will face towards the center rear of the cart as shown.

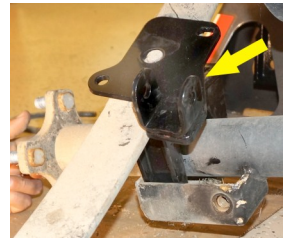

11. Slide the New U-bolt through the shock mounting plate, over the rear axle and through the original leaf spring plate. Tighten the assembly evenly on each side using (2) 10mm Flat Washers and (2) 10mm Lock Nuts. Adjust alignment if necessary.
12. Attach the leaf spring to the rear shackle using the Original Hardware. Adjust the axle position if needed for alignment.
13. Attach the shock to the shock mounting plate using the Original Bolt, (1) 10mm Lock Nut and (1) 10mm Washer.
14. Repeat steps 1-13 for the passenger side rear suspension.
15. Tighten all hardware left loose in this section.

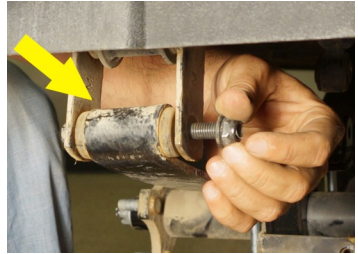
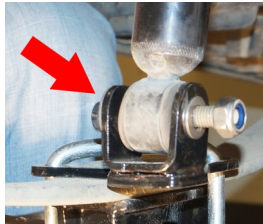
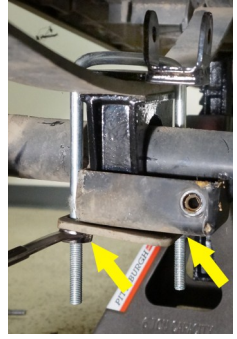

16. If the cart is not high enough to accommodate the larger tires and wheels, raise the cart to the correct height with the jack.
17. Install the (2) rear tires/wheels on the rear hubs.
18. Remove the jack stands and lower the cart.
19. Remove the jack.

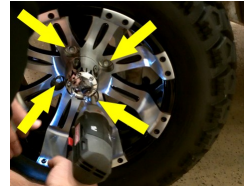

Gas Carts Only:

1. Carefully raise the jack to support the rear axle.
2. Starting on the driver side, disconnect the bottom of the shock from the axle and push the shock out of the way. Retain hardware.
3. With the rear axle supported by the jack, disconnect the leaf spring at the rear shackle. Retain hardware.
4. Make sure the front wheels are chocked and release the parking brake. Remove and release BOTH brake cables from the rear axle by removing the cotter pins and the pins holding them in place. Release the passenger side

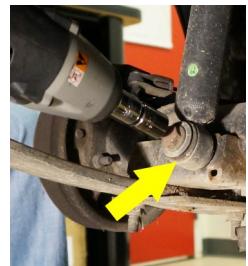

brake cable by loosening the jam nut. Release the driver side brake cable by pushing the tabs inward on the brake cable to allow it to fit through the bracket.

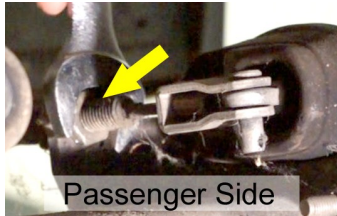

5. Loosen both nuts on the driver side U-bolt then carefully remove the U-bolt. Discard the U-bolt and retain the leaf spring plate.
6. Remove the front portion of the leaf spring by removing the bolt on the front shackle. Remove the leaf spring. Retain hardware.

7. Carefully lower the jack to lower the rear axle away from the chassis. Do not remove the jack stands. They will support the chassis.



8. Remove the driver side hub by removing the cotter pin and the castle nut. If the hub cannot be removed by hand, use a hub puller, which can be purchased at a local auto store. Retain hardware.
9. Remove the (2) bolts on the brake assembly connected to the brake cable bracket. Discard bracket. Retain hardware.
10. Install the new brake cable bracket in the same location where the original one was removed using the Original Hardware. Tighten.

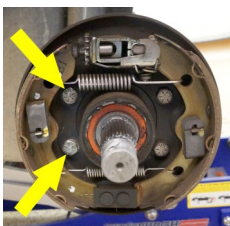

11. Reinstall the hub onto the axle using the Original Castle Nut. Tighten fully. If the cotter pin hole is not entirely visible through the castle nut's gaps, keep tightening. Backing off the nut could strip the hub over time.



12. Once the hole and castle nut are aligned, insert the Cotter Pin. Do not reconnect the brake cable.
13. Place the leaf spring on top of the axle.
14. Reattach the front portion of the leaf spring to the front shackle using the Original Hardware. Do not fully tighten.

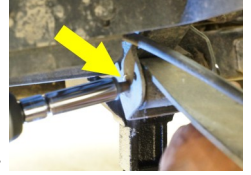

15. Place a riser block on top of the axle and under the leaf spring. When oriented correctly, the wider leg will be towards the front of the cart and the pin on the bottom of the leaf spring will seat into the hole on top of the riser block. Slightly loosening the opposite U-bolt and adjusting the axle position will help with alignment.



16. Once the spring is seated, identify the new driver side shock mounting plate included in the BMF kit. Place it on top of the leaf spring. The pin will seat in the small center hole. The shock mounting tabs will face towards the center rear of the cart as shown.

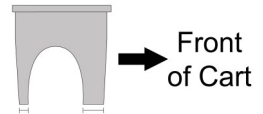

17. Slide the New U-bolt through the shock mounting plate, over the rear axle and through the original leaf spring plate. Tighten the assembly evenly on each side using (2) 10mm Flat Washers and (2) 10mm Lock Nuts. Adjust alignment if necessary.

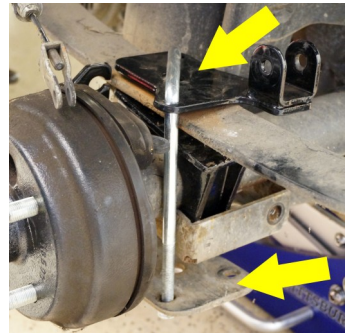

18. Attach the leaf spring to the rear shackle using the Original Hardware. Adjust the axle position if needed for alignment.



19. Attach the shock to the shock mounting plate using the Original Bolt, (1) 10mm Lock Nut and (1) 10mm Washer.

20. Repeat steps 1-3, 5-7 and 13-19 for the passenger side rear suspension.

21. Tighten all hardware left loose in this section.



Reroute Brake Cable—Gas Carts Only:

1. Remove the driver side upper and lower rocker panels (shown in yellow) Retain panels and hardware.
2. Remove the floor mat over the pedal area (shown in blue). Retain rivets.
3. Remove the pedal cover plate (shown in orange). Retain rivets.
4. Locate the brake cable furthest on the driver side (shown in orange). Push the tabs on the cable inward to release it from the bracket. Rotate the cable and push the end down to release it from the equalizer.

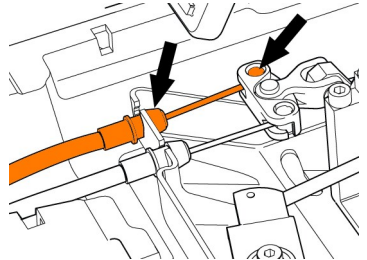
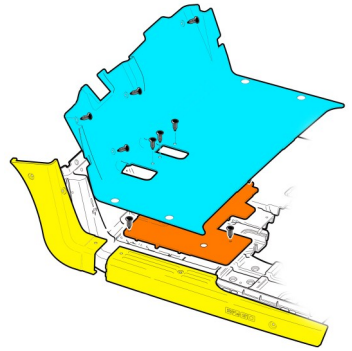

5. Gently pull the driver side brake cable completely out of the cart.
6. Under the driver side of the cart, locate the plastic channel on the outside edge of the chassis. Using a sharp cutting tool, cut an opening in the channel large enough to fit the end of the brake cable (shown in blue to the right).



7. Feed the original brake cable, rear end first, into the channel and through the newly drilled hole.



8. Push the front portion of the brake cable through the brake cable bracket and expand the tabs. Reattach the end to the equalizer.
9. Loosely attach the brake cable to the extra hole in the front leaf spring shackle with a wire tie to prevent it from swaying excessively under the cart.
10. Push the rear end of the brake cable through the new brake cable bracket on the hub and expand the tabs. Put the pin back in its original location and reinstall the original cotter pin.

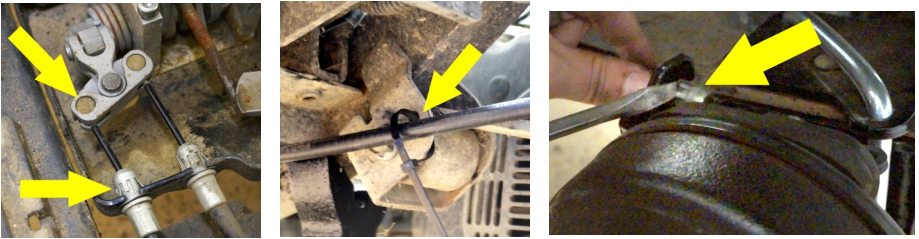

11. Reinstall the pedal cover plate, floor mat and rocker panels using the Original Hardware.

Engine Mount Bracket Installation—Gas Carts Only:

1. Place the jack under the engine.
2. Place jack stands securely under both sides of the rear axle for extra support.
3. Begin removing the original engine mount by removing the M10 bolt going through the center of the assembly (shown in pink). Retain all hardware.
4. Remove the upper weldment mount (orange) by removing the (2) nuts holding it in place. Discard hardware and mount.
5. Remove all delrin washers (purple), rubber washers (yellow), cap adapters (dark blue) and the compression spring (green). Retain all items.
6. Remove the lower weldment mount (light blue) by removing the (2) bolts holding it in place. Retain hardware and discard mount.

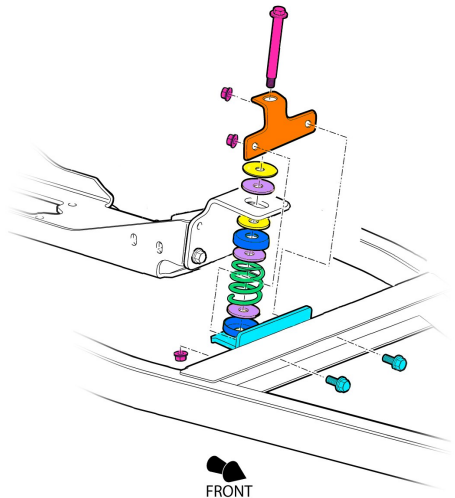

7. Place the new engine mount bracket where the lower weldment mount was removed. The engine mount tab will face the rear. Install the engine mount bracket using the Original Hardware. Tighten the bolts.

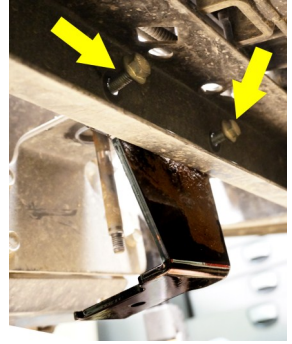

8. Place the Original M10 Bolt through the front engine mount hole. Lower the jack until the bolt threads extend through small hole on the new engine mount bracket.

9. Place all washers, cap adapters and the compression spring in their original locations in relation to the front engine mount and the new engine mount bracket. Fasten the Original M10 Bolt and Nut. Adjust the height of the engine if necessary for alignment.

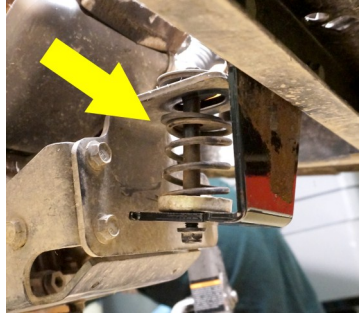

10. After the engine mount bracket is completely installed, remove the jack stands from the rear axle.

11. If the cart is not high enough to accommodate the larger tires and wheels, raise the cart to the right height with the jack.

12. Install the (2) new rear tires/wheels on the rear hubs.

13. Remove the jack stands and lower the cart.

14. Remove the jack.



Adjust the Toe and Camber

1. Drive forward and back 20-40 feet to check the toe and camber before making adjustments. Only make adjustments if needed.

NOTE: For stability, an 1/8" toe-in with a positive camber is recommended. This will level out when the cart is loaded.

2. Adjust the camber by changing the mounting position of the shock in the shock tower. Mounting the



shock close to the outside of the cart will make the camber more positive. Mounting it close to the inside of the cart will make the camber more negative.

- Adjust the toe by loosening the jam nut then lengthen or shorten the tie rod by turning the hex shaped rod adjustment. Shortening the tie rods increases the toe-in, lengthening decreases it.



- Once camber and toe adjustments are finalized and set, tighten all hardware and jam nuts.

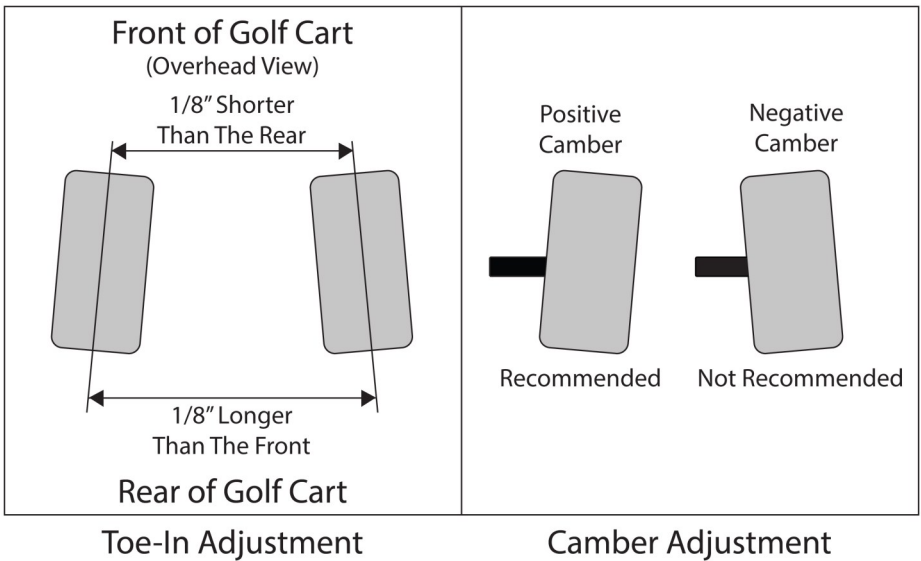

Front Bumper Modification

- Cut the bumper template along the cut lines. This will be used as a guide to trim the sides of the bumper.
- Tape the template onto the passenger side of the bumper. The thicker line will line up with the outer edge of the bumper.



3. Using a marking tool, trace the template onto the bumper on the line that reads "CUT BUMPER ON THIS LINE".
4. Remove the template and cut the bumper with a sharp saw (i.e. jig saw). The blue portion below is what will be removed on each side.
5. Turn the template over and repeat steps 2-4 for the passenger side of the bumper.
6. Use sand paper to smooth any rough edges left from the saw.

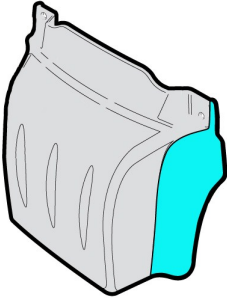

7. Reinstall the front bumper using the Original Hardware.



This completes the installation of your E-Z-Go RXV BMF Lift Kit.
Please enjoy safely!

Watch this installation and others on YouTube:
www.youtube.com/user/GolfCartInstructions